

HANDI-MOVE MODEL 2600

MOBILE HOIST VICTOR

For intensive and super fast use



- Lifts twice as fast
- Designed for intensive use
- Electrically adjustable base
- Usable in combination with various spreader bars, slings and Body Support
- Lifts from floor to high surfaces
- Aluminium construction for easy care
- Exchangeable battery box or direct charging
- Optional digital scale



Handi-Move INTERNATIONAL

SPECIALISTS IN INNOVATIVE AND RELIABLE LIFT & CARE SYSTEMS

TECHNICAL SPECIFICATIONS

DIMENSIONS AND SPECIFICATIONS

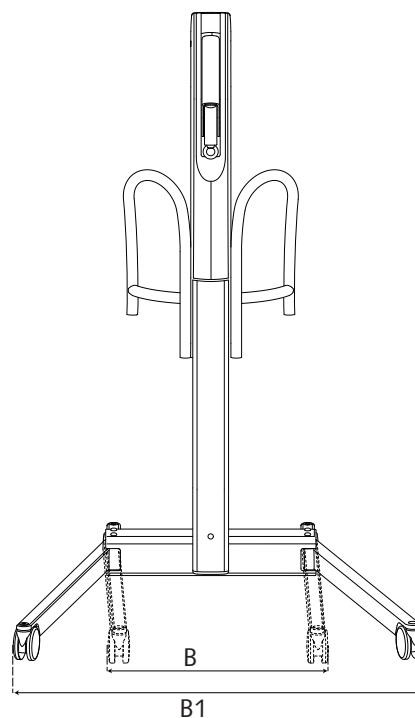
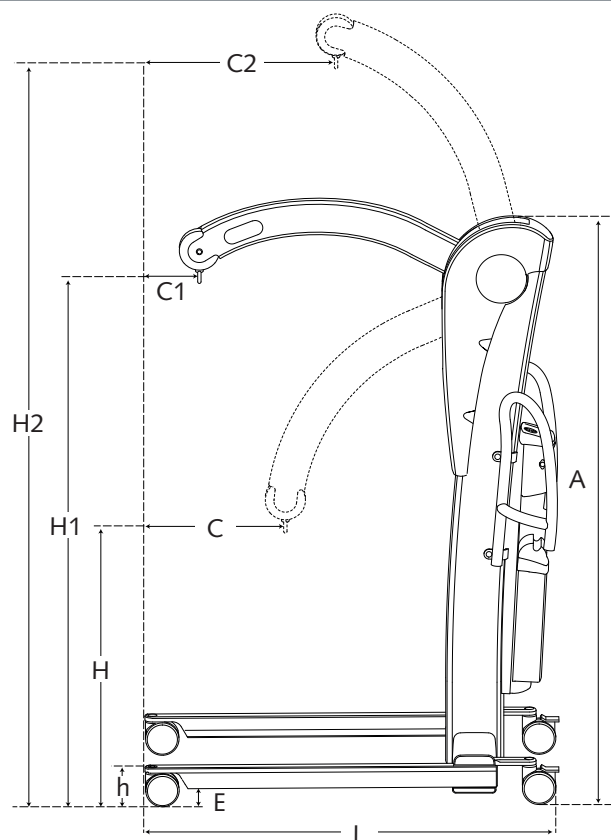

Dimensions (in mm)

A	B	B1	H	H1	H2	h	C	C1	C2	L	E
1725	635	1100	775	1530	2240	120	440	170	620	1230	54

Technical data

Construction.....	aluminium; gloss finish
Covers.....	ABS
Weight.....	58 kg
Motor/actuator.....	24 Vdc, 13 A
.....	electric/hydraulic
Weight batterybox.....	6,2 kg
Safe working load.....	225 kg
Emergency switch.....	present
Wheels:.....	front \varnothing 100 mm
.....	rear \varnothing 100 mm with brakes
.....	can be disassembled for maintenance
Emergency down.....	mechanical
Noise.....	68 dBA
Battery-indicator.....	acoustic
Batteries.....	2x12 Vdc; 7.2 Ah
Charger.....	in:..... 0.9 A 100 - 240 VAC
.....	50 - 60 Hz, klasse II
.....	out:..... 24 Vdc
.....	Max 1.3 A
Number of lifts when fully charged.....	160 lifts with 90 kg/distance 50 cm
Safety class.....	IPx0
Charging time after signal.....	4 hours
Wall-mount charger.....	optional
Extra battery box.....	optional

Speed up

without load.....	6,9 cm/sec
charge 90 kg.....	6,3 cm/sec
charge 225 kg.....	4.5 cm/sec

Speed down

without load.....	6.3 cm/sec
charge 90 kg.....	5.8 cm/sec
charge 225 kg.....	5 cm/sec

For free demonstration or further information :

