

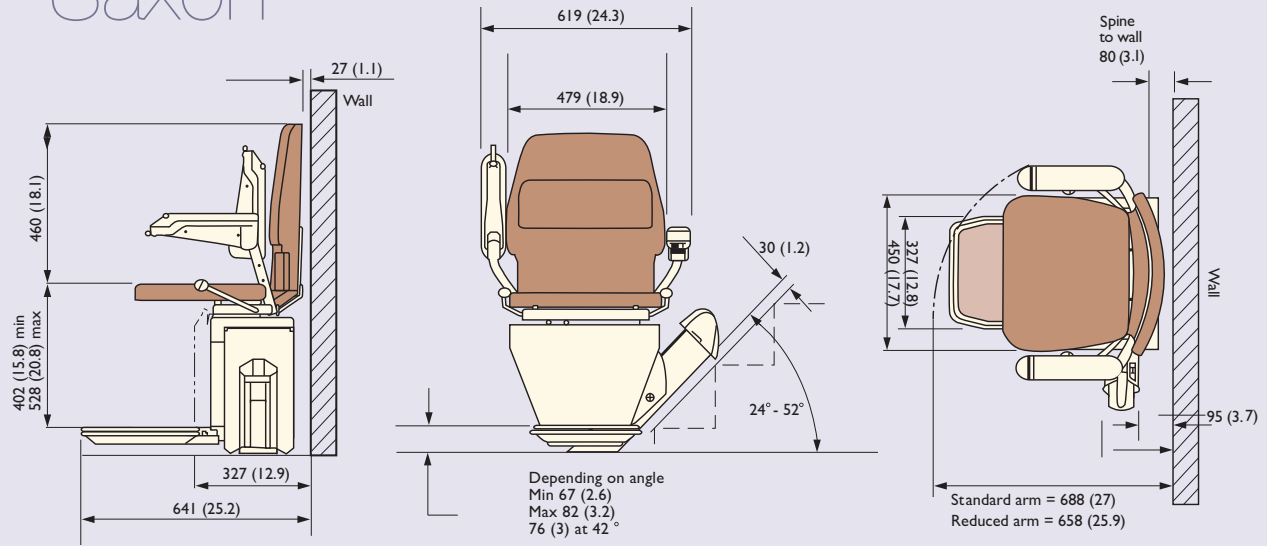

Saxon

Saxon



Sofia

Sofia and Solus

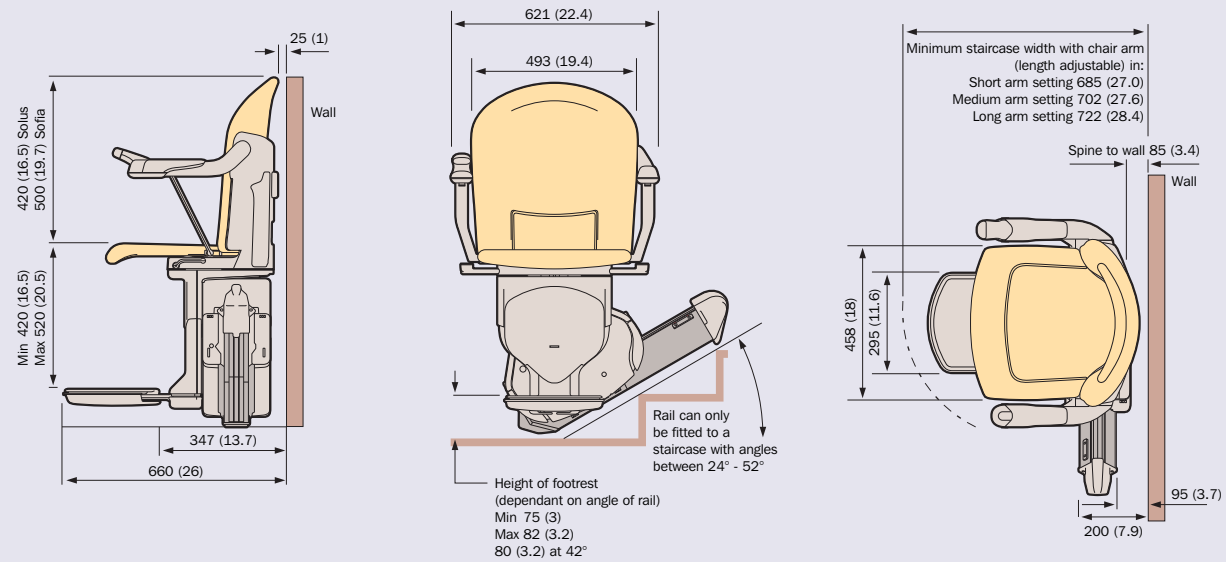

Solus

All dimensions measured from the wall are nominal. The addition of a wide stringer or similar obstruction may affect the dimensions taken from this point. Measurements are in millimetres. Measurements in brackets are inches.

The Stannah range for straight stairs



HINGED RAIL

If the stairlift rail obstructs your hallway, the stairlift can be fitted with a Standard or Automatic hinged rail which folds up out of the way.

Solus and Sofia

SEAT

Seat Type	Armchair seat – swivels to face landing
Materials	Steel frame, with flame retardant upholstery
Armrests	Two sturdy armrests with soft polyurethane upper surface
Switches	One removable 'on/off' key at the end of arm. Light-touch control pod for up/down, 'on/off' rocker switch on arm. Master power switch mounted on rear of carriage
Load	52° 135kg
Power Swivel Control	Control pod operated at the top of the rail

FOOTREST

Construction	Cast aluminium alloy
Finish	Epoxy powder-coated ABS plastic safety edge
Carpet	Pile with latex back, conforms to BS4790
Safety	Safety pads operate safety switches in direction of travel
Folding	Powered by lifting arm or seat

Saxon

SEAT

Seat Type	Armchair seat – swivels to face landing
Materials	Steel frame, with flame retardant upholstery
Armrests	Two sturdy hinged armrests with soft polyurethane upper surface. One housing directional controls, one housing 'on/off' rocker switch
Switches	One removable 'on/off' key under arm. Light-touch joystick for up/down, 'on/off' rocker switch on arm. Battery isolator switch mounted on carriage
Load	Up to 42° 160kg (approx 25 stone) 42°-49° 135kg (approx 21 stone) 49°-52° 120kg (approx 19 stone)
Power Swivel Control	Joystick operated at the top of the rail

FOOTREST

Construction	Cast aluminium alloy
Finish	Epoxy powder-coated ABS plastic safety edge
Carpet	Pile with latex back, conforms to BS4790
Safety	Safety pads operate safety switches in direction of travel
Folding	Cable link to arm

Saxon, Solus and Sofia

RAIL

Construction	Extruded aluminium rail
Finish	Choice of Silver or Bronze
Fixing	Brackets screwed to staircase
Min Length of Rail	1.2 metres
Max Length of Rail	8.0 metres
Rail Section Size	105mm wide x 112 high
Normal distance of rail from skirting	95mm
Stair Nose to rail	30mm
Rail Overhang at top	Short rail overhang available at all angles
Rail wiring	Inside rail
Drive Method	Rack and pinion
Max, Rail Incline	52°

CARRIAGE

Construction	Steel fabrication. ABS plastic covers
Finish	Epoxy powder-coated
Motor Output 0.27KW	DC powered, input 24V DC @750mA
Start	Cushioned start/stop
Speed	0.1m/sec+ 20%
Electronics	Electronic control unit
Safety Features	Overspeed governor stops stairlift at 0.3m/s max. Safety pads operate safety switches located around carriage. Stairlift works in event of power cuts
Servicing	BS requirement is annually
Batteries	2 x 12V 7.6Ah
Noise Level (dBA)	Maximum operating level, 70 dBA

OTHER FITTINGS

Landing Call Switches	Surface-mounted controls at top and bottom of stairs have push-button 'up/down' switches
Charge Unit	Wall or floor mounted, 24V two stage unit

Find out more about Stannah Stairlifts. Visit our website at www.stannah.com

Stannah Stairlifts, Watt Close, East Portway, Andover, Hampshire SP10 3SD Tel: (01264) 332244 Fax: (01264) 338043

OUR COMPANY POLICY IS ONE OF CONTINUING PRODUCT IMPROVEMENT. WE THEREFORE RESERVE THE RIGHT TO ALTER THE SPECIFICATIONS AND TO CHANGE AND IMPROVE DESIGN AT ANY TIME. FULL OPERATING INSTRUCTIONS ARE SUPPLIED FOR ALL PRODUCTS. STANNAH IS A REGISTERED TRADEMARK. THE CE MARK INDICATES THAT THIS PRODUCT COMPLIES WITH THE APPLICABLE EUROPEAN DIRECTIVES WHICH RELATE TO HEALTH, SAFETY, ENVIRONMENT AND CONSUMER PROTECTION. DESIGN, MANUFACTURE AND INSTALLATION: STANNAH STAIRLIFTS LIMITED WERE THE FIRST STAIRLIFT MANUFACTURER TO OBTAIN FULL QUALIFICATION TO BRITISH STANDARD BS5750 (ISO 9001) SAFETY AND RELIABILITY: AN EXAMPLE OF THIS PRODUCT HAS BEEN INDEPENDENTLY TESTED AND APPROVED TO BS5776 (1996).



© Stannah Stairlifts Ltd. Not to be reproduced wholly or in part without the written permission of Stannah Stairlifts Ltd.

TECH.0905

Stannah
Better by design